

**DOCUMENT CONTROL NUMBER**

/

**MF601Ex INTRINSICALLY SAFE ION CHAMBER SMOKE DETECTOR****PRODUCT APPLICATION AND DESIGN INFORMATION****1. INTRODUCTION**

The MF601Ex Intrinsically Safe Ion Chamber Smoke Detector forms part of the M600Ex series of plug in detectors for ceiling mounting. The detector plugs into the Minerva MUBEx base and is intended for two-wire operation with the majority of control equipment currently manufactured by the company.

**WARNING:**

**THESE DETECTORS CONTAIN A SMALL AMOUNT OF RADIOACTIVE MATERIAL - (Americium 241). DETECTORS ARE SAFE UNDER THE PRESCRIBED CONDITIONS OF USE BUT MUST NOT BE DISMANTLED BY UNAUTHORISED PERSONS. STORAGE AND TRANSPORT OF DETECTORS MUST BE ARRANGED IN ACCORDANCE WITH GOVERNMENTAL SAFETY REGULATIONS.**

**2. INTRINSIC SAFETY**

The detectors are designed to comply with EN 50 014 and EN50 020 for intrinsically safe apparatus. They are certified:

ATEX code:  II 1 G

Cenelec code: EEx ia IIC T5

under ATEX certificate number BAS01ATEX1134X.

These detectors are designed and manufactured to protect against other hazards as defined in paragraph 1.2.7 of Annex II of the ATEX Directive 94/9/EC.

**2.1 DETECTOR USE**

It is recommended that the detector is used in conjunction with a suitable isolator or shunt diode safety barrier in a certified Intrinsically Safe system, ie, System 601.

**3. OPERATING PRINCIPLE CHAMBER**

The MF601 uses an ionisation chamber to detect the presence of aerosol combustion products generated in fires, ionised air within the chamber is affected by these products such that an imbalance occurs increasing the potential of the collector. The chamber is represented diagrammatically in Fig. 1.

The small radioactive source (<33.3kBq of Americium 241) ionises the air within the volume enclosed by the slotted outer cover. The ionisation causes a small current to flow between the source and the cover which have a fixed voltage applied between them.

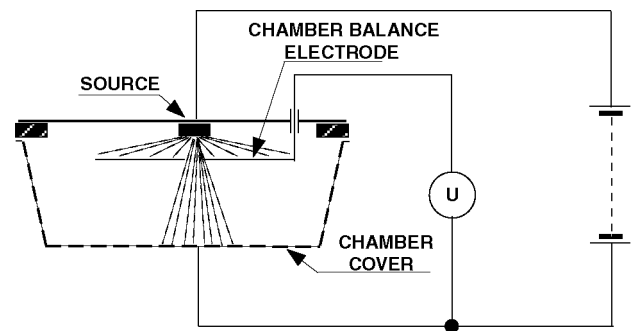
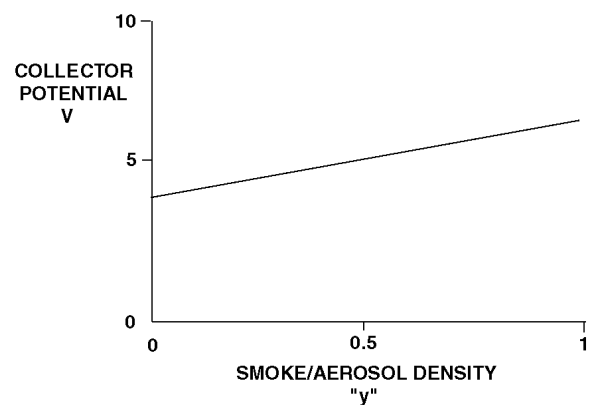

**Fig. 1 Representational Diagram of Ion-Chamber**

Within the chamber is a perforated electrode known as the collector. This electrode will, under clean air conditions, assume a certain potential relative to the outer cover. This potential is due to the radioactive emissions ionising the air and is relatively stable.

If smoke/aerosols are introduced into the chamber they effect the ionised air, such that an imbalance occurs increasing the potential of the collector. The magnitude of this potential can be used to indicate the smoke density, see Fig. 2. The current that flows across the chamber is very small and the device used to sense the potential of the collector must, therefore, be of very high impedance.

To ensure high stability and resistance to corrosion, all metal parts of the chamber are of stainless steel and the critical insulators are of PTFE.



**Fig. 2 Graph showing Collector Potential Relative to Smoke/Aerosol Density**

# M600 SERIES

01B-04-D10

1 7/02

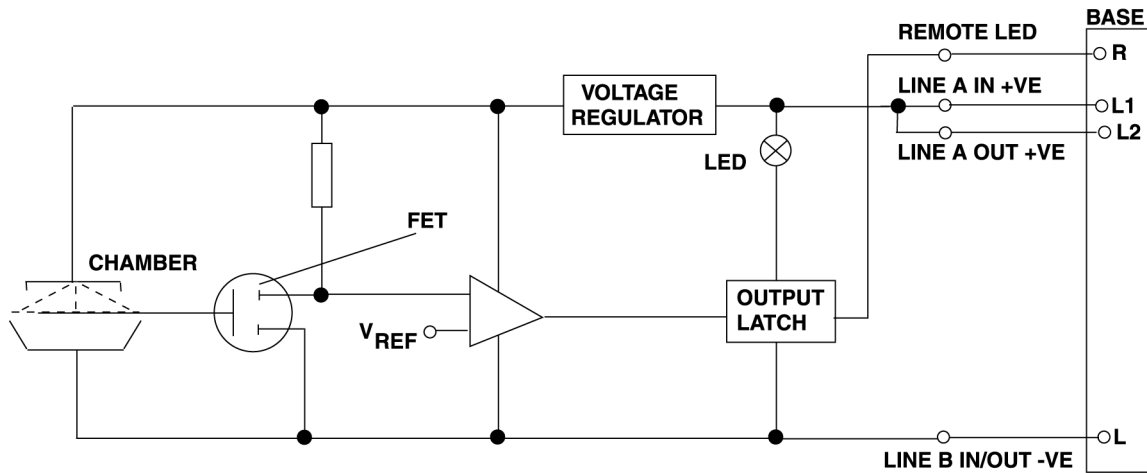

Fig. 3 Simplified Block Schematic Diagram of Detector

## 3.1 CIRCUIT

### 3.1.1 STANDARD VERSION DETECTORS

A simplified block schematic is given in Fig. 3.

The voltage of the collector electrode of the chamber is buffered by the FET stage and compared with a factory-set reference voltage. When the collector voltage continuously exceeds the preset reference level, which determines the sensitivity of the detector, the comparator output changes state.

This change of state causes the output switch to draw extra current from the supply to signal an 'Alarm' condition and to light the integral alarm indicator.

All critical parts of the circuit are fed by an internal voltage regulator to make the sensitivity independent of the supply voltage over a wide range.

## 3.2 WIRING

Loop cabling is connected to base terminals as follows:

L	-VE
L1	+VE IN
L2	+VE OUT
R	Remote LED Drive

## 4. MECHANICAL CONSTRUCTION

The major components of the detector are:

- Body Assembly
- Printed Circuit and Ion Chamber
- Ion Chamber Cover
- Light Pipe
- Outer Cover

## 4.1 ASSEMBLY

The body assembly consists of a plastic moulding which has four embedded detector contacts, aligning with contacts in the MUBEx base. The moulding incorporates securing features to retain the detector in the base.

- The PCB is soldered to the body.
- The chamber cover is clipped to the body.
- The light pipe is slotted into the chamber cover. Finally, the outer cover is clipped to the body.

## 4.2 PRINTED CIRCUIT/CHAMBER ASSEMBLY

All electronic components, including the alarm LED indicator, complete chamber assembly and FET buffer are mounted on a single printed circuit board. The underside of the PCB is epoxy encapsulated so that critical components and conductors are protected against corrosion and mechanical shock.

The printed circuit/chamber assembly has a baffle and closure ring added and is fitted inside the body assembly and secured to the detector cover.

The baffle, in conjunction with the outer cover, is carefully designed to allow easy entry to smoke and at the same time, to minimise the effects of wind on the chamber.

## 4.3 FINAL ASSEMBLY

The assembly described in para 4.2 is, in effect, a complete detector but the remaining components provide further protection against external influences.

The insect screen is fitted over the outer cover of the chamber to prevent the entry of insects which would cause false alarms.

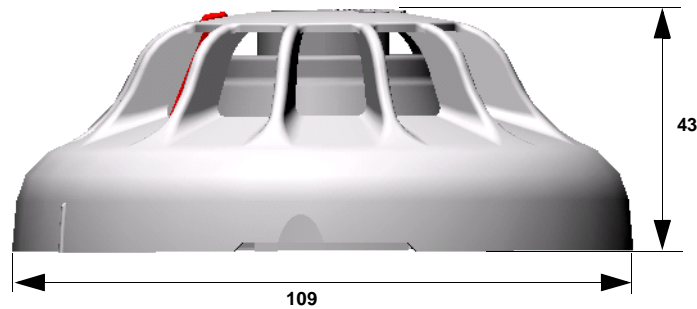

**Fig. 4 Overall Dimensions of MF601Ex Detector**

## 5. TECHNICAL SPECIFICATION

### 5.1 MECHANICAL

#### Dimensions

The dimensions of the MF601Ex detector are shown in Fig. 4.

#### Materials

Body and Cover: FR110 'BAYBLEND'  
flame resistant

Chamber Components: Bright stainless Steel to BS 1449: Pt 2 Grade 316 S16, PTFE and Polycarbonate

#### Weight

Detector: 0.142kg  
Detector plus base: 0.206kg

### 5.2 ENVIRONMENTAL

Operating Temperature: -20°C to +70°C  
but see note.

#### Note:

**1) The operating temperatures quoted exceed the ATEX Certification limits.**

**2) Operation below 0°C is not recommended unless steps are taken to eliminate condensation and hence ice formation on the detector.**

Storage Temperature: -40°C to +80°C

Relative Humidity: up to 95% non-condensing

Shock: }  
Vibration: } EN54 Part 7  
Impact: }  
Corrosion: }

### 5.3 ELECTROMAGNETIC COMPATIBILITY

The detector complies with the following:

Product family standard EN50130-4 in respect of Conducted Disturbances, Radiated Immunity, Electrostatic Discharge, Fast Transients and Slow High Energy

EN50081-1 for Emissions

### 5.4 ELECTRICAL

Characteristics	Min.	Typ.	Max.	Unit
Operating Voltage (dc)	16		28	V
Quiescent Current	45		50	uA
Switch-on-Surge	-	-	200	uA
Stabilisation Time	-	15	30	sec
Alarm Current	See Fig. 5			mA
Holding Current	-	-	1	mA
Holding Voltage	-	-	5	V
Reset Time	0.5	1	2	sec
Remote LED drive	via 3.4k resistor			

**Table. 1 Electrical Characteristics**

#### Intrinsic Safety Rating:

Maximum Voltage for safety (U<sub>i</sub>): 28V  
Maximum Current for Safety (I<sub>i</sub>): 93mA  
Maximum Power Input (P<sub>i</sub>): 650mW  
Equivalent Inductance (L<sub>i</sub>): 0  
Equivalent Capacitance (C<sub>i</sub>): 0

# M600 SERIES

01B-04-D10

1 7/02

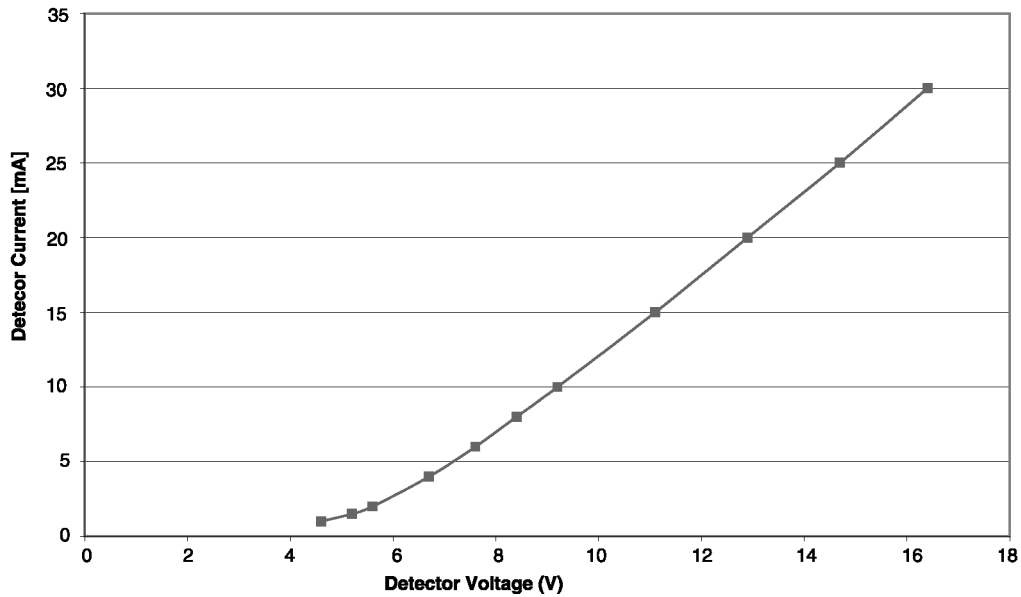

Fig. 5 The Alarm Load

The characteristics shown in Table 1 are taken at 25°C with an operating voltage of 20V unless otherwise specified. The alarm load presented to the controller by the detector is shown in Fig. 5.

## 5.5 PERFORMANCE CHARACTERISTICS

The fundamental parameter in defining the performance of a smoke detector is the level of smoke which will just produce an alarm under 'ideal' conditions. This parameter, known as the response threshold value, is normally measured in a smoke tunnel in which the smoke density is monitored by a standard ionisation chamber. Smoke density is expressed as a 'y' value which is proportional to the aerosol concentration.

Also of importance is the built-in time delay which ensures that no alarm will be given until the smoke density has exceeded the response threshold value for a certain length of time. Such a delay is useful for the elimination of transient effects although the sensitivity of the detector to real fires is also affected.

Typical response threshold values and response delays are given in Table 2.

DESIGNATION	RESPONSE THRESHOLD VALUE Y	RESPONSE DELAY sec.
MF601Ex	0.7	8

Table. 2

The MF601Ex is suitable for general applications especially where materials are very inflammable.

The effect of wind, atmospheric pressure and temperature on the detectors is discussed in Sections 5.5.1 to 5.5.3.

### 5.5.1 THE EFFECT OF AIRFLOW ON DETECTOR SENSITIVITY

The MF601Ex detector has been specifically designed not to give false alarms when subjected to draughts or gusts of wind which may be experienced due to an open window, etc.

In general, in areas where continuous forced ventilation exists, it is recommended that:

- a) Standard sensitivity detectors may be fitted where the airflow is less than 5m/s.

The MF601Ex detector exceeds the airflow requirements of EN54 Pt 7.

### 5.5.2 THE EFFECT OF TEMPERATURE ON DETECTOR SENSITIVITY

The detector includes electronic temperature compensation. The detector sensitivity is substantially constant over its specified operating range.

### 5.5.3 THE EFFECT OF ATMOSPHERIC PRESSURE ON SENSITIVITY

Atmospheric pressure reduces with altitude. The effect of this is to reduce the sensitivity of the detector as the altitude increases, (see Fig. 6). It is recommended that MF601 is not used for installations sited above 1500m.

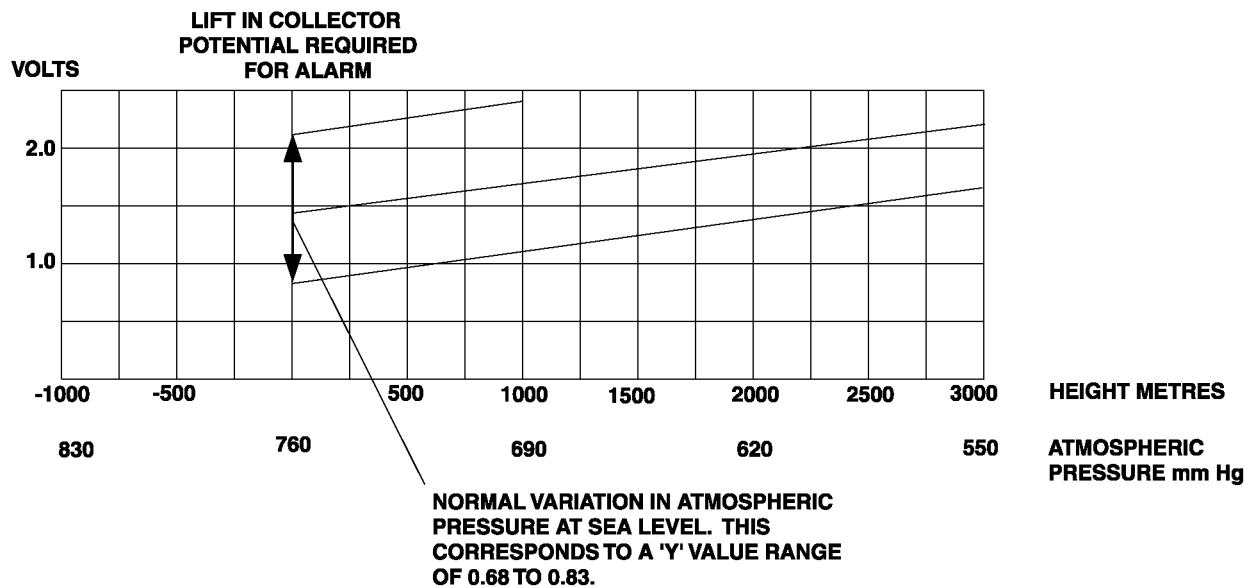

**Fig. 6 Graph to Show Change in Detector Sensitivity with Atmospheric Pressure**

**5.6 RESPONSE TO FIRE TESTS**

The response of a detector to real or large-scale test fires will be partly dependent upon its Response Threshold Value and its Response Delay. Other factors, however, such as the smoke entry characteristic of the detector and the rate of development of the fire, the thermal lift of the fire and the type of smoke it produces, are also important. For this reason, smoke detectors are subjected to test fires covering a range of fire types.

The tests are defined in BS 5445: Pt 9 which also defines the way in which detector sensitivity is classified. Three classes are used: A, B and C, where A is the highest sensitivity. If the detector does not respond, or responds inadequately, to a test fire it is not classified, ie, (N).

The MF601Ex detector passes the following Fire Tests:

- TF1 open cellulosic (wood-flaming)
- TF2 smouldering pyrolysis
- TF3 glowing smouldering (cotton)
- TF4 open plastics (polyurethane foam)
- TF5 liquid (n-heptane)

**Table. 3 Test Results for MF601Ex Detector**

*Note: TF2 to TF5 are the mandatory test fires required to meet BS5445 Pt 7 (EN54 Pt 7).*

**6. DETECTOR IDENTIFICATION**

The detector is identified by the logo label, as shown in Fig. 7.

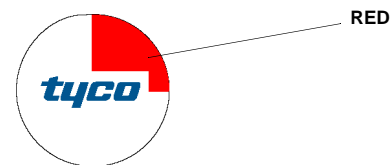

**Fig. 7 Detector Identification**

**7. ORDERING INFORMATION**

- MF601Ex Intrinsically Safe Ion Chamber Smoke Detector: 516.050.004.Y
- MUBEx Base for use with Ex Detectors: 517.050.610

JM/em  
 2<sup>nd</sup> July 2002