



G010512

System: CFD5000

Loop Controller Module

CS-Loop M H

Part no. 5210003-00A

General description

The CS-Loop M H module is intended to be used as a part of a fire detection system and is suitable for use in SIL 1 and SIL 2 environments.

This loop-line controller module offers one loop-line interface that is capable of handling 150 addressable loop units. It is designed to comply with the standards for the industrial, maritime, offshore and rolling stock markets up to Safety Integrity Level 2 (SIL 2).

The module communicates via the IDAxt protocol on the loop-line and the SSP protocol if connected with other CS-modules.

The IDAxt protocol uses a frequency modulation interface to transmit data; this and the signal processing capability of this module ensure very modest cable requirements for installations.

The CS-Loop M H can control the loop-line in normal or redundant configuration. Each CS-Loop M H furthermore has:

- Redundant power supply inputs
- Redundant communication channels
- A channel for transmitting the fire condition

For details on assembling a system and definitions of common system terms, please see the Installation & Commissioning manual.

The CS-Loop M H module consists of two products, the CS-Loop M and the CS-Housing 22.5 H, which can be ordered separately as spare parts.

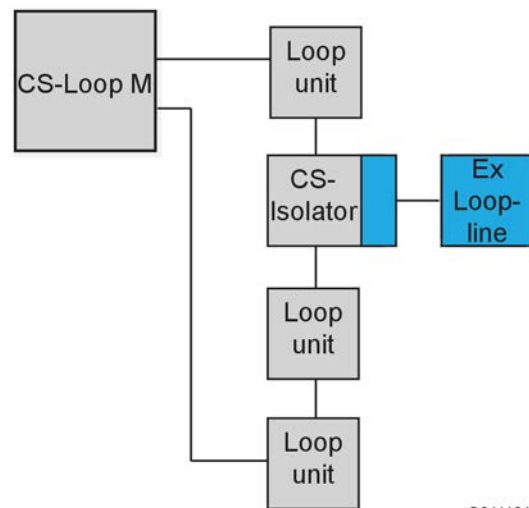

G011101

Figure 1. Example of a normal loop-line configuration

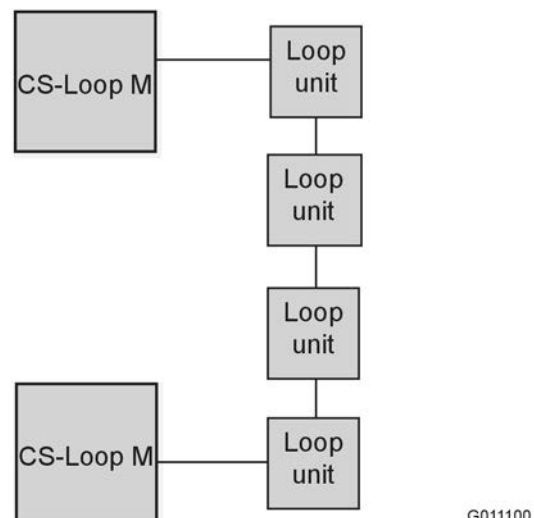

G011100

Figure 2. Example of a redundant loop-line configuration with two CS-Loop M H modules

Data

Operating voltage	19–30 VDC
Current consumption (at 24 V)	70 mA
Loop line output:	
- Nominal voltage	35 VDC
- Max. output current	400 mA (< 15 minutes)
- Continuous output current	200 mA
Max. no. of loop units	150
Cable terminals	2.5 mm ²
Operating temperature	-40 °C to +70 °C
Storage temperature	-50 °C to +70 °C
Relative humidity	≤ 95 % RH non-condensing
Addressing method	DIP switch
Material	Nylon 6.6
Weight (with housing)	≈140 g
Colour	Yellow (RAL 1018)
Spare part no. CS-Loop M (without housing)	5210002-00A
Spare part no. for housing	5210069-00A
Loop cable requirement	See the Installation & Commissioning manual
Compatible loop units	All loop units that communicates with the IDAxt protocol
CE Conformity	EN 54-2
Certified according to	 2531/yy yy = year of production



G011098

Functional Safety Data

Type	B
HFT	0
SFF	97 %
PFD _{avg}	1.96 × 10 ⁻⁴

PFD_{avg} is calculated for MTTR 8 h and proof test interval 1 year.

Suitable for use in SIL 1 and SIL 2 environments.

Settings

The module is identified by a physical address on the Backbone Bus. The address is set with an 8-pole DIP switch.

Address switch

The DIP switch value follows the binary system. The address no. can be set from 1 to 126 using DIP-switch poles 1 to 7.

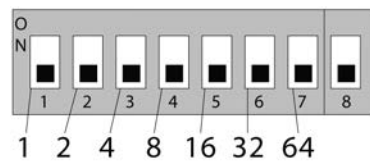

G000668

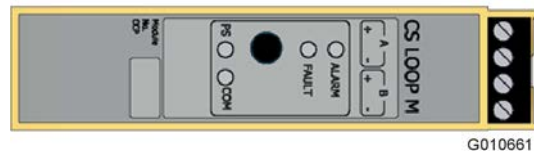
Connections

G010661

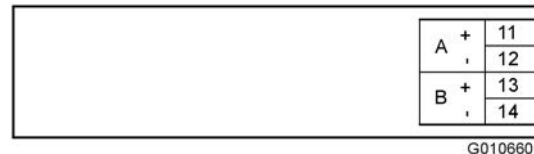

G010660

Connection examples

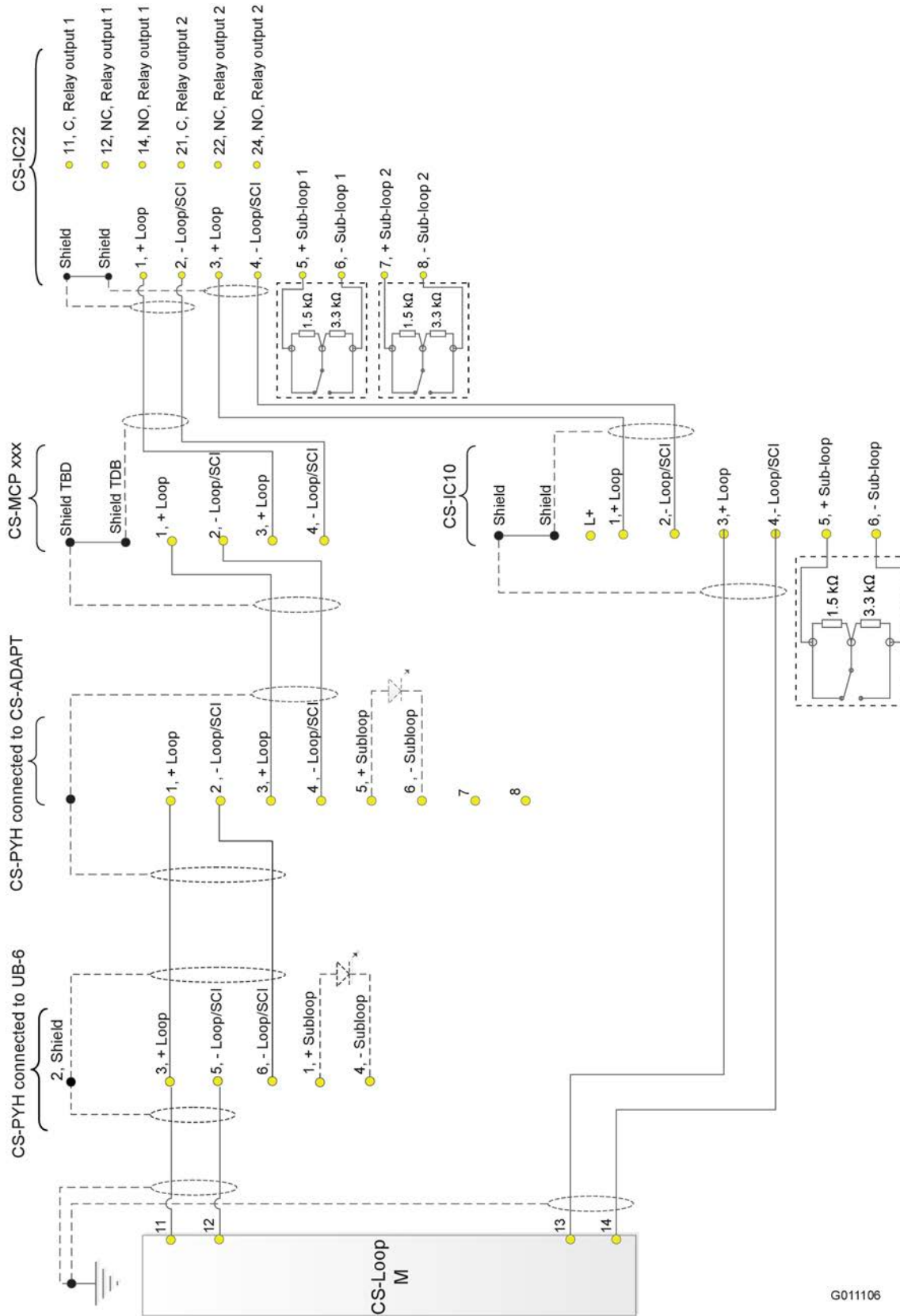

G011106

Figure 3. Connection example of a normal loop-line configuration in a non Ex area

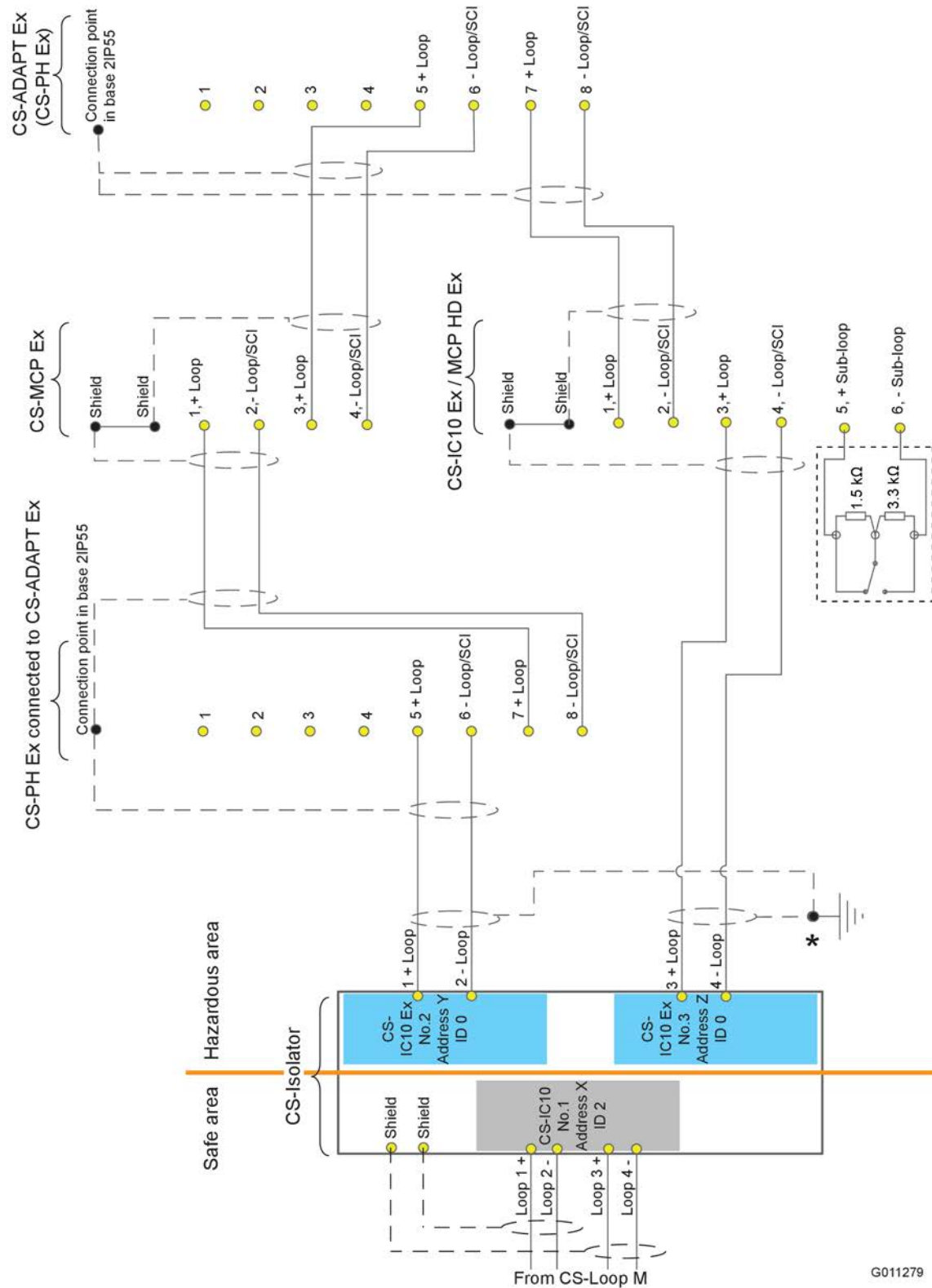

G011279

Figure 4. Connection example for an Ex loop-line

* External earth connection for CS-Isolator



CAUTION!

If a shielded cable is used on the loop-line it shall be connected to the shield terminal on CS-IC10. The shield from the loop-line shall not be connected with the shield from the hazardous area.

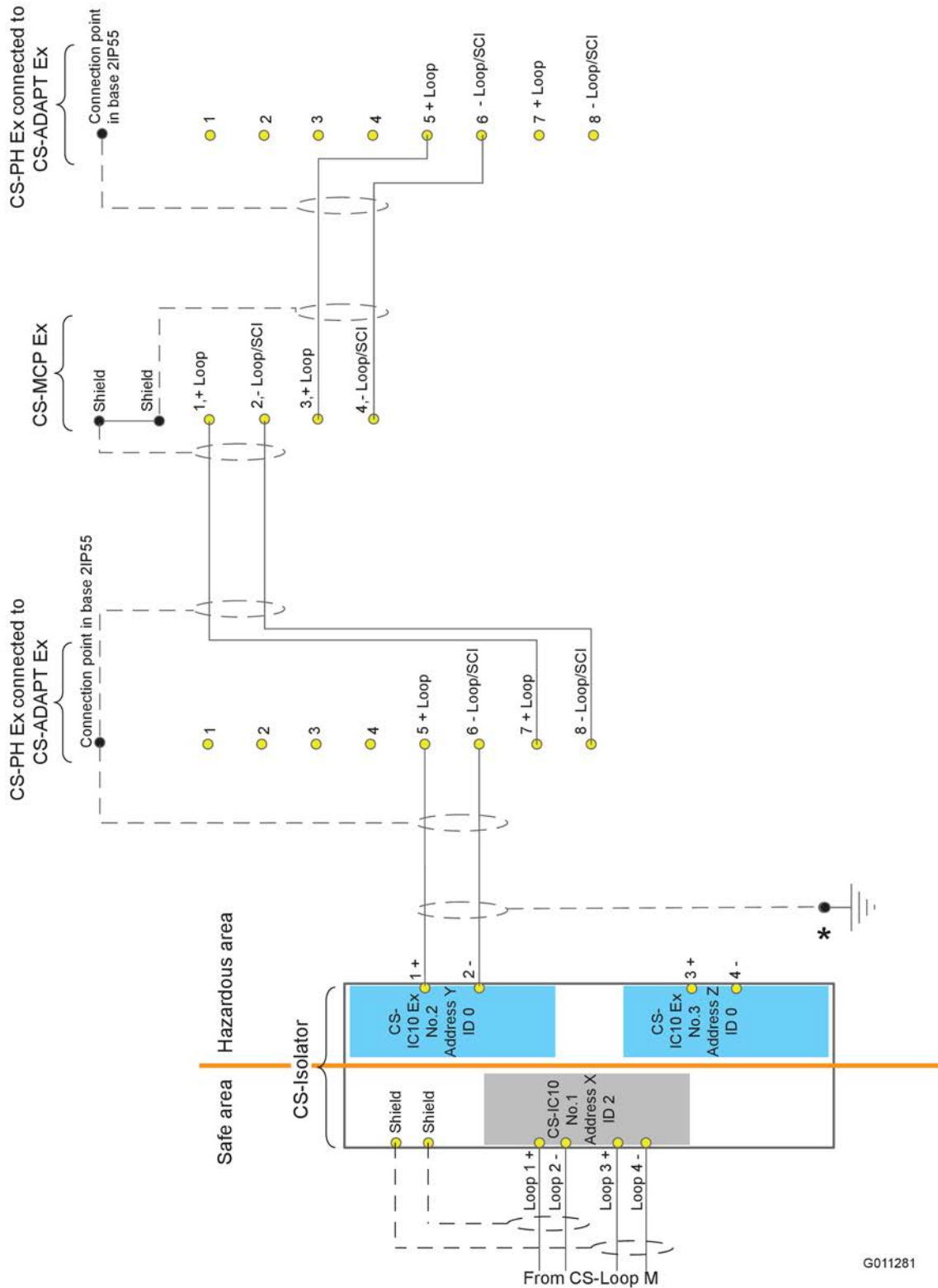

Figure 5. Connection example for an Ex spur

* External earth connection for CS-Isolator



CAUTION!

If a shielded cable is used on the loop-line it shall be connected to the shield terminal on CS-IC10. The shield from the loop-line shall not be connected with the shield from the hazardous area.

Indicators

CS-Loop M indicators display output and alarm status.

Front label	Indicator	Colour; pattern	Module status	Failure classification
	ALARM	Red, steady	One or more fire alarms are present	Follow local procedures
		Red, flashing	Pre-alarm	Follow local procedures
		None	There are no alarms	N/A
	FAULT	Yellow, steady	One or more faults are present	*
		Yellow, flashing	Module is booting or re-scanning the loop	*
		None	There are no faults	N/A
	PS (Power Supply)	Green	OK	N/A
		Yellow, steady	Power fault on one of the two power channels feeding the module. A single power fault does not prevent the loop module to communicate with the loop units.	Minor fault*
		Yellow, flashing: 0.5 sec On, 0.5 sec Off.	Boot loader mode. Only active during firmware download to the loop module. In this mode the loop unit can't communicate with the loop units.	*
		Yellow, flashing: 1 sec On, 0.5 sec Off.	Safe State Predefined state to avoid disturbing system integrity.	*
	COM (Backbone communication)	Green, steady	OK	N/A
		Green, flashing	Unconfigured. Could be a configuration error in the application program file. (Communication working.)	Minor fault*
		Yellow, steady	System fault.	Major fault*
		Yellow, flashing	Communication fault on the backbone interface.	Major fault*
		None	No communication	Major fault*
PS + COM (both flashing)	PS Yellow, flashing	Transferring software. (Download or upload.)	*	
	COM Green, flashing			

* Check fault alarm on the control panel and refer to fault code information in CFD5000 Installation & Commissioning manual or Service & Maintenance manual.



NOTE!

If all LED's are flashing the DIP switches are set to OFF or all are set to ON.
Please set according to project documentation.

Dimensions (mm)

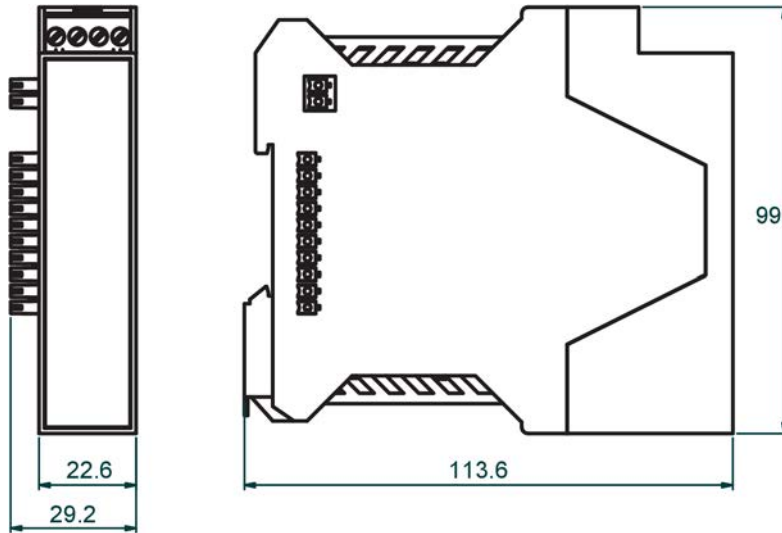

G010658

Mounting

Mount the module on a horizontal 35 mm DIN rail.