

# 2.85" Diameter Electrical Slip Ring

Model 180

Focal Technologies Corporation, a Moog Inc. company, has over 30 years of expertise in supplying standard and custom marine products for harsh environments and is a leading manufacturer of high performance and high quality electrical slip rings. Contact Focal for assistance in selecting the best solution for your requirement.



Please note diagram shows model 180 with optional connectors

The Model 180 is comprised of electrical power and signal passes, and provides superior performance and reliability in demanding operational environments. The slip ring is waterproof rated to IP66, with the option for greater ingress protection.

The Model 180 may be constructed for subsea use where underwater operation is required. The slip ring may be fluid-filled, and pressure compensated unit.

For hazardous locations, the Model 180-X variant is fully certified as a flameproof and explosion proof enclosure.

## Features

- Standard electrical passes rated up to 1000 V / 7 A
- 1500V passes optional
- Pigtail exits are capable of being sealed
- Can accommodate a variety of wire and cable types
- Maintained type certification for Hazardous locations
- Rugged design intended for harsh environments
- Reliable operation under shock and vibration
- Underwater designs available

## Benefits

- Compliance with the highest quality standards for design, manufacture and test
- Maintenance free operation
- More than 30 years of proven field performance
- Integration with fiber optic rotary joints and fluid rotary unions to provide a complete rotating interface solution

## Applications

- Winch cable reels and TMS applications
- Remotely Operated Vehicles (ROVs)
- Oceanographic winches (surface and subsea)
- Industrial machinery
- Land based oil and gas

# Specifications

Electrical	
<b>Voltage</b>	1000 VAC standard 1500 VAC optional
<b>Current</b>	Maximum 7 A per pass Maximum 100 A total current
Electrical Performance	
<b>Contact Resistance</b>	20 mΩ nominal
<b>Insulation Resistance</b>	Typically > 500 MΩ @ 1 kVDC
<b>Signal Types</b>	Analog Video, CanBus, Profibus, Device Net, 10 Base-T Ethernet, SHDSL, RS-485, 1000 Base-T Ethernet, 100 Base-T Ethernet
Mechanical	
<b>Rotation Speed</b>	Maximum 100 rpm
<b>Ingress Protection</b>	Sealed to IP66, except for pigtail exits
<b>Operating Temperature</b>	-20°C to +55°C
<b>Housing</b>	Stainless steel (304)
<b>Insertion Length "L" (see drawing below)</b>	Varies with number of electrical passes
Environment Test	
<b>Temperature</b>	Tested to MIL-STD-810F Methods 501.4 and 502.4
<b>Vibration</b>	Tested to MIL-STD-167-1
<b>Shock</b>	Tested to MIL-STD-810D, method 516.3
<b>Humidity</b>	Tested to MIL-STD-810F, method 507.4

Please contact factory with your application details

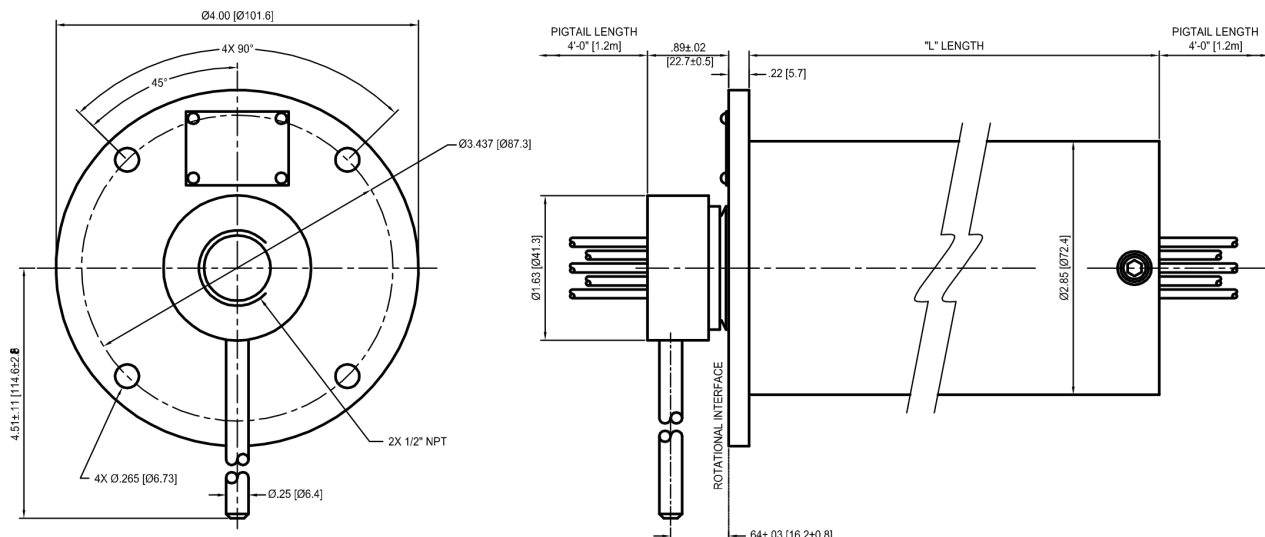

Hazardous Area Option: Model 180-X	
<b>Certifications</b>	<p><b>US:</b> Class I, Division 1, Group C &amp; D, T5 Class I, Zone 1, AEx db IIB T5 Gb ETL ATM 4007859</p> <p><b>CAN:</b> Class I, Division 1, Group C &amp; D, T5 ETL ATM 4007859 Ex db IIB T5 Gb ETL22CA105073054X</p> <p><b>ATEX:</b> CE 0344 Ⓢ II 2 G Ex db IIB T5 Gb ETL 23 ATEX 0295X</p> <p><b>GB:</b> UKCA 8505 Ⓢ II 2 G Ex db IIB T5 Gb ITS 22 UKEX 0584X</p> <p><b>IECEX:</b> Ex db IIB T5 Gb ETL 13.0013X</p>
Terminations	
<b>Standard</b>	Wire pigtails, 4 ft [1.2 m], exiting via 1/2" or 3/4" NPT female ports
<b>Special</b>	Supply and installation of connectors, terminals, conduit, cable, glands, junction boxes, sealed pigtail exits
Additional Options	
<b>Optics</b>	Fiber Optic Rotary Joint (FORJ) or optical converter
<b>Design Classification</b>	ABS, DNV, BV, LRS
<b>Submersed Applications</b>	Fluid fill fittings or fluid filled/ pressure compensated at factory
<b>Other Devices</b>	RF Rotary Joint, shaft encoder, sensors, Fluid Rotary Union, customer supplied product
<b>Ingress Protection</b>	IP 67 or IP 68
<b>Housing Material</b>	316 stainless steel
<b>Certifications</b>	Intrinsically safe (IS)

All specifications and information are subject to change without notice. Please contact Focal for the latest updates.

Dimensions in inches [mm]

© 2023 Moog Inc. DS180-v3.0

[www.moog.com/focal](http://www.moog.com/focal)

Focal Technologies Corporation, A Moog Inc. Company