

Isolating Switching Amplifier MS1-33Ex0-R 3-channel

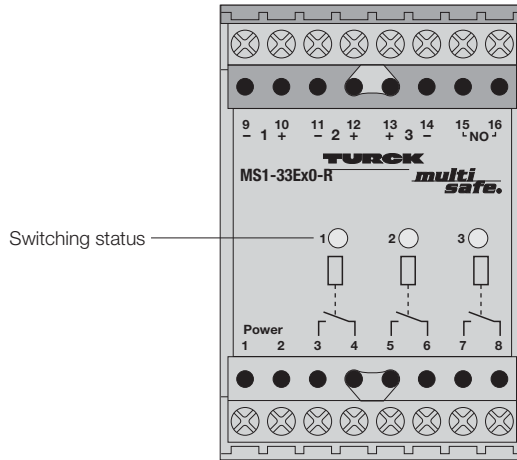

1

- **3-channel isolating switching amplifier**
- **Intrinsically safe input circuits EEx ia**
- **Area of application according to ATEX: II (1) GD, I (M1)**
- **Galvanic isolation between input circuits, output circuits and supply voltage**
- **3 relay outputs, each with one NO contact**
- **Selectable NO/NC output function**
- **Universal supply voltage (20...250 VAC/20...125 VDC)**

The MS1-33Ex0-R switching amplifier is a 3-channel device with intrinsically safe input circuits. They can be connected to sensors according to EN 60947-5-6 (NAMUR), variable resistors or potential-free contacts. All three output circuits have individual relays with one NO contact.

The selected output mode applies to all three channels. Program for normally closed (NC/R) mode by leaving terminals 15 and 16 open, or normally open (NO/A) mode by jumpering terminals 15 and 16 (I).

This unit does not have input circuit monitoring. Therefore, this device provides an inexpensive alternative in systems which use NAMUR sensors or mechanical contacts.

The MS1-33Ex0-R switching amplifier has an alternate configuration used to multiply outputs. This is achieved by connecting a single input device to terminals 15 and 16 (II). All three relay outputs will then operate in parallel according to the selected output mode (each output is programmed by linking the appropriate input channels).

The yellow LEDs indicate the switching status of the outputs.

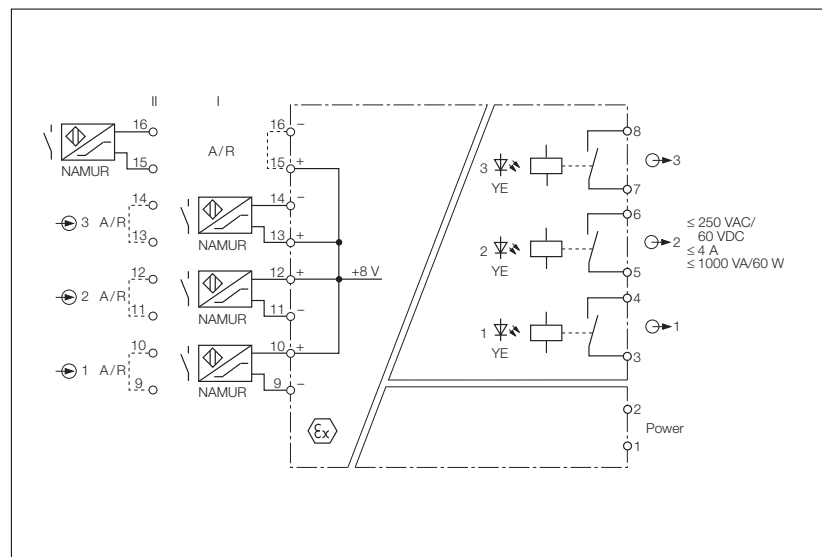

Isolating Switching Amplifier MS1-33Ex0-R

Type	MS1-33Ex0-R
Ident-no.	5313102
Supply voltage U_B	20...250 VAC/20...125 VDC
Line frequency (AC)	40...70 Hz
Power consumption	≤ 3 W
Galvanic isolation	between input circuit, output circuit and supply voltage for 250 V _{rms} , test voltage 2.5 kV _{rms}
Input Circuits	acc. to EN 60947-5-6 (NAMUR), intrinsically safe according to EN 50020
Operating characteristics	
– Voltage	8 V
– Current	8 mA
Switching threshold	1.55 mA
Hysteresis	0.2 mA
Output Circuits	3 relay outputs
Contacts	1 NO contact, silver-alloy + 3 μm Au
Switching voltage	≤ 250 VAC/60 VDC
Switching current	≤ 4 A
Switching capacity	≤ 1000 VA/60 W
Switching frequency	≤ 10 Hz
Ex-approval acc. to certificate of conformity	DMT 01 ATEX E 119
Maximum nominal values	
– No load voltage U_0	11.0 V
– Short-circuit current I_0	55 mA
– Power P_0	150 mW
– Safety voltage U_m	250 VAC/125VDC
Max. external inductances/capacitances L_0/C_0	
– [EEx ia] IIC	1 mH/500 nF
– [EEx ia] IIB	3 mH/2500 nF
– [EEx ia] I	10 mH/10 μF
Marking of device	Ⓔ II (1) GD [EEx ia] IIC I (M1) [EEx ia] I
LED Indications	
– Switching status	3 x yellow
Housing	50 mm wide, Polycarbonate/ABS
Mounting	panel mounting or snap-on clamps for top-hat rail (DIN 50022)
Connection	2 x 8 self-lifting pressure plates
Connection profile	≤ 2 x 2.5 mm ² or 2 x 1.5 mm ² with wire sleeves
Degree of protection (IEC 60529/EN 60529)	IP20
Operating temperature	-25...+60 °C

